

CITY OF LAREDO SPECIAL CITY COUNCIL MEETING

**A-2017-SC-03
CITY COUNCIL CHAMBERS
1110 HOUSTON STREET
LAREDO, TEXAS 78040
April 11, 2017
5:30 P.M.**



DISABILITY ACCESS STATEMENT



Persons with disabilities who plan to attend this meeting and who may need auxiliary aid or services are requested to contact Heberto "Beto" L. Ramirez, Acting City Secretary, at (956) 791-7308 at least two working days prior to the meeting so that appropriate arrangements can be made. The accessible entrance and accessible parking spaces are located at City Hall, 1100 Victoria Ave.

Out of consideration for all attendees of the City Council meetings, please turn off all cellular phones and pagers, or place on inaudible signal. Thank you for your consideration.

Pursuant to the Texas Penal Code (trespass by holder of license to carry a handgun), a person licensed under Subchapter H, Chapter 411, Government Code (Concealed Handgun Law or Handgun Licensing Law), may not enter into the City Council Chamber while City Council is in session with a concealed or openly-carried handgun.

I. CALL TO ORDER

II. PLEDGE OF ALLEGIANCE

III. MOMENT OF SILENCE

IV. ROLL CALL

Citizen comments

Citizens are required to fill out a witness card and submit it to the City Secretary no later than 5:45 p.m. and identify themselves at the microphone. Comments are limited to three (3) minutes per speaker. No more than three (3) persons will be allowed to speak on any side of an issue. Should there be more than three (3) people who wish to speak on a particular issue, they need to select not more than three (3) representatives to speak for them and the presiding

officer may limit the public comments further in the interest of an orderly meeting. Speakers may not pass their minutes to any other speaker. Comments should be relevant to City business and delivered in a professional manner. No derogatory remarks will be permitted.

V. STAFF REPORTS

1. Staff Report on the Outlet Shoppes at Laredo Marketing in Monterrey.
2. Presentation by JBS Water, Inc. on summary findings of their 2016 report, Comprehensive Water Distribution and Meter Management Audit.
3. Presentation regarding the late fees exemption for Veterans, with possible action.

VI. RECESS AS THE LAREDO CITY COUNCIL AND CONVENE AS THE LAREDO MASS TRANSIT BOARD

4. Consideration for approval of the El Metro Operations and Maintenance Building Roof Replacement and Building Improvements as complete, approval of change order no. 1, a decrease of \$1,446.78 and to add one hundred seven (107) calendar days to the construction contract time, release of retainage and approval of final payment in the amount of \$54,303.83 to ABBA Construction, LLC., Laredo, Texas. Final construction contract amount is \$948,343.22. Funding is available in the Transit Capital Grants Fund/FTA Grant.

VII. ADJOURN AS THE LAREDO MASS TRANSIT BOARD AND RECONVENE AS THE LAREDO CITY COUNCIL

GENERAL COUNCIL DISCUSSIONS AND PRESENTATIONS

A. Request by Mayor Pete Saenz

1. Status on Community Calendar.
2. Report on What Works Cities 2017 Summit.

B. Request by Council Member Rudy Gonzalez, Jr.

1. Discussion with possible action to integrate special needs programs at the recreation centers.

C. Request by Mayor Pro-Tempore Alejandro "Alex" Perez

1. Update on utility repairs and resurfacing of Lane street in the Heights area.

D. Request by Council Member Alberto Torres, Jr.

1. Discussion with possible action to develop a City ordinance that prohibits mobile snack trucks from conducting business past a certain hour; and any other matters incident thereto.
2. Discussion with possible action to explore the possibility of establishing a Special Needs Recreation Center and Community Fine Arts & Culture Center in District 4; and any other matters incident thereto.
3. Discussion with possible action to install speed humps along the 3800 to 4400 block of E. San Francisco Ave. under the Special Provision of the Speed Hump Installation Policy, adopted by City ordinance, utilizing District IV funding.

E. Request by Council Member Nelly Vielma

1. Discussion with possible action to request a report by the Internal Auditor of the current contractor's insurance, bond, lapses and tax delinquencies with the City. **(Co-Sponsored by Council Member George Altgelt)**

F. Request by Council Member Charlie San Miguel

1. Discussion with possible action regarding the Public's Health and Safety specific to the issuing and enforcement of permits applying to building, electrical, mechanical HVAC, irrigation, right-of-way, swimming pool, manufactured home installation, sign contractors; and any other matters incident thereto.

G. Request by Council Member George Altgelt

1. Discussion with possible action to request a report by Internal Auditor of the current franchise agreements including but not limited to timely and complete quarterly and annual report filings, timely payment of franchise or other fees to the City, insurance requirements, lapses and tax delinquencies with the City. **(Co-Sponsored by Council Member Charlie San Miguel and Council Member Nelly Vielma)**
2. Discussion with possible action to allow amusement redemption machine establishments in the Central Business District (CBD) and the Arts and Entertainment District (A&E) by right. **(Co-Sponsored by Council Member Roberto Balli and Council Member Nelly Vielma)**

H. Request by Council Member Roberto Balli

1. Discussion with possible action regarding a downtown street musician and street performance ordinance tailored to the Downtown Arts & Entertainment District.
2. Discussion with possible action regarding proposals on the Boulevard of the Americas Project.

VIII. EXECUTIVE SESSION

The City Council hereby reserves the right to go into executive session at any time during this public meeting, if such is requested by the City Attorney or other legal counsel for the City, pursuant to his or her duty under Section 551.071(2) of the Government Code, to consult privately with his or her client on an item on the agenda, or on a matter arising out of such item.

IX. ADJOURNMENT

This notice was posted at the Municipal Government Offices, 1110 Houston Street, Laredo, Texas, at a place convenient and readily accessible to the public at all times. Said notice was posted on Friday, April 7, 2017 at 5:00 p.m.

Heberto "Beto" L. Ramirez
Acting City Secretary

City Council-Special

Meeting Date: 04/11/2017

Initiated By: Cynthia Collazo, Deputy City Manager

Staff Source: Blasita Lopez

SUBJECT

Staff Report on the Outlet Shoppes at Laredo Marketing in Monterrey.

PREVIOUS COUNCIL ACTION

N/A

BACKGROUND

N/A

COMMITTEE RECOMMENDATION

N/A

STAFF RECOMMENDATION

N/A

Fiscal Impact

Fiscal Year:

Budgeted Y/N?:

Source of Funds:

Account #:

Change Order: Exceeds 25% Y/N:

FINANCIAL IMPACT:

N/A

City Council-Special

Meeting Date: 04/11/2017

Initiated By: Robert Eads, Assitant City Manager

Staff Source: Riazul I. Mia, P.E., CFM - Utilities Director

SUBJECT

Presentation by JBS Water, Inc. on summary findings of their 2016 report, Comprehensive Water Distribution and Meter Management Audit.

VENDOR INFORMATION FOR COMMITTEE AGENDA

JBS, Inc completed city of Laredo's last Water Audit in 2007.

PREVIOUS COUNCIL ACTION

On May 16, 2016 Council approved authorizing the City Manager to negotiate a contract for the Comprehensive Water Distribution & Meter Management Audit with JBS Water, Inc.

BACKGROUND

Request For Qualifications (RFQ) were advertised on March 23, 2016 and the RFQ was closed on April 15, 2016. A total of four (4) licensed engineering firms responded to the request and staff from various departments reviewed the submittals and ranked the qualified firms based on: 1) Previous Experience; 2) Qualification of team; and, 3) Approach to work.

COMMITTEE RECOMMENDATION

NA

STAFF RECOMMENDATION

NA

Fiscal Impact

Fiscal Year: 2017

Bugeted Y/N?:

Source of Funds:

Account #:

Change Order: Exceeds 25% Y/N:

FINANCIAL IMPACT:

No financial impact.

City Council-Special

Meeting Date: 04/11/2017

Initiated By: Robert Eads, Assistant City Manager

Staff Source: Riazul I Mia, P.E. Utilities Director

SUBJECT

Presentation regarding the late fees exemption for Veterans, with possible action.

PREVIOUS COUNCIL ACTION

City Council requested information on Veterans with water accounts for possible exemption of late fees.

BACKGROUND

City Council requested information on Veterans with water accounts for possible exemption of late fees.

COMMITTEE RECOMMENDATION

NA

STAFF RECOMMENDATION

NA

Fiscal Impact

Fiscal Year: 2017

Budgeted Y/N?: N/A

Source of Funds:

Account #:

Change Order: Exceeds 25% Y/N:

FINANCIAL IMPACT:

No financial impact.

City Council-Special

Meeting Date: 04/11/2017

Initiated By: Jesus Olivares, City Manager

Staff Source: Rogelio Rivera, P.E., City Engineer; Claudia San Miguel, Acting Transit General Manager

SUBJECT

Consideration for approval of the El Metro Operations and Maintenance Building Roof Replacement and Building Improvements as complete, approval of change order no. 1, a decrease of \$1,446.78 and to add one hundred seven (107) calendar days to the construction contract time, release of retainage and approval of final payment in the amount of \$54,303.83 to ABBA Construction, LLC., Laredo, Texas. Final construction contract amount is \$948,343.22. Funding is available in the Transit Capital Grants Fund/FTA Grant.

PREVIOUS COUNCIL ACTION

On March 21, 2016, City Council approved a construction contract to the lowest bidder ABBA Construction, LLC., Laredo, Texas, in the amount of \$949,790.00 (which includes the base bid and alternates no. 1 and 2) for the El Metro Operations and Maintenance Building Roof Replacement and Building Improvements (Re-Bid) with a construction contract time of one hundred fifty (150) calendar days.

BACKGROUND

The original project consisted of: A) the complete replacement of the present built up and decking roofing system (approx. 16,500 SF) for the El Metro Fleet Maintenance Building with a new standing seam metal panel roof system over new tapered rigid insulation board and "Tectum" decking panels; B) installing a new retro-fit insulated metal standing seam panel system over an existing metal panel system for the El Metro Operations Center (approx. 8,400 SF); with C) Add Alternate No. 1 – new metal engineered canopies to the south side bay doors of the Fleet Maintenance Building and D) Add Alternate No. 2 - Interior Remodeling of the Center's Restrooms and Dressing Rooms.

Plans and specifications were prepared by Sepulveda Associates Architects, Inc., Laredo, Texas.

This change order no. 1 is for the balance of quantities actually constructed in place and to add one hundred seven (107) calendar days to the construction contract time.

Original construction contract	
--------------------------------	--

(Approved by City Council on March 21, 2016)	\$949,790.00
This change order no. 1	\$(1,446.78)
Final construction contract amount	\$948,343.22

COMMITTEE RECOMMENDATION

N/A.

STAFF RECOMMENDATION

Approval of Motion.

Fiscal Impact

Fiscal Year: 2017
Budgeted Y/N?: Yes
Source of Funds: Transit Capital Grants
Account #: 518-5189-583-2010
Change Order: Exceeds 25% Y/N:

FINANCIAL IMPACT:

Funding is available in the Transit Capital Grants Fund.
 FTA Grant TX-03-0274 – Account No. 518-5189-583-2010
 FTA Grant TX-04-0047 – Account No. 518-5193-583-2010

Fiscal Year: 2017
Budgeted Y/N?: Yes
Source of Funds: Transit Capital Grants
Account #: 518-5193-583-2010
Change Order: Exceeds 25% Y/N:

FINANCIAL IMPACT:

Attachments

Site Map and Change Order No. 1

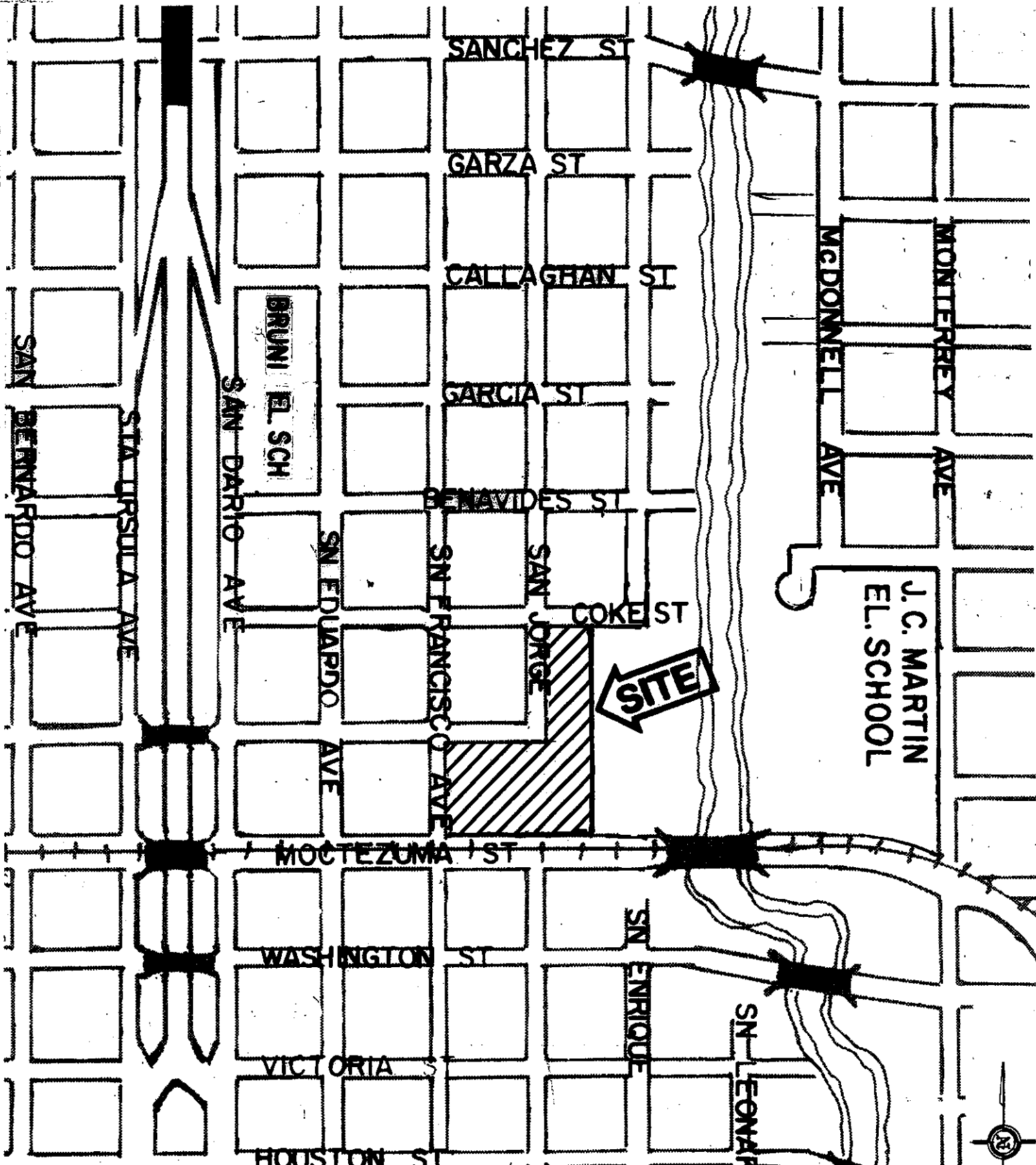

CONSIDERATION FOR APPROVAL OF THE EL METRO OPERATION AND MAINTENANCE BUILDING ROOF REPLACEMENT AND BUILDING IMPROVEMENTS AS COMPLETE, APPROVAL OF CHANGE ORDER No. 1, RELEASE OF RETAINAGE, AND APPROVAL OF FINAL PAYMENT

City Council Meeting
April 3, 2017

CITY OF LAREDO
ENGINEERING DEPARTMENT
1110 HOUSTON ST. P.O. BOX 579 PH. 781-7346 FAX (210) 791-7496

AGENDA ITEM



Document G701™ – 2001



Change Order

PROJECT: (Name and address)	PROJECT NUMBER: 2012-11	OWNER <input checked="" type="checkbox"/>
El Metro Operations & Maintenance Roof	CONTRACT FOR: \$949,790.00	ARCHITECT <input type="checkbox"/>
Replacement Bldg. Improvements	CONTRACT DATE: 03/21/14	CONTRACTOR <input type="checkbox"/>
TO OWNER: (Name and address) City of Laredo 1110 Houston St. Laredo, Texas 78040	TO CONTRACTOR: (Name and address) ABBA Construction, LLC 201 W. Hillside Rd. Ste. 6 Laredo, TX 78041	FIELD <input type="checkbox"/>
		OTHER <input type="checkbox"/>

The Contract is changed as follows:
(Include, where applicable, any undisputed amount attributable to previously executed Construction Change Directives)

(See Attached)
 ITEM No. 1 Time Extension 107 Calendar Days
 ITEM No. 2 Credit Contingency Allowance Balance Amount.....=\$ 446.78
 ITEM No. 3 Unit Pricing Eave Galvanized Steel Angle 100LF x \$10.00 per LF Credit amount.....=\$1,000.00
Total Credit Amount \$1,446.78

Original Contract Sum	\$ 949,790.00
Decrease Net Allowance Balance (- \$ 1,446.78)	
Balance Contract Sum	\$ 948,343.22

The original (Contract Sum) (Guaranteed Maximum Price) was	\$ <u>949,790.00</u>
The net change by previously authorized Change Order	\$ <u>.00</u>
The (Contract Sum) (Guaranteed Maximum Price) prior to this Change Order was	\$ <u>949,790.00</u>
The original (Contract Sum) (Guaranteed Maximum Price) will be (increased) (decreased) (unchanged) by this Change Order in the amount of	\$ <u>(-\$1,446.78)</u>
The new (Contract Sum) (Guaranteed Maximum Price) including this Change Order will be	\$ <u>948,343.22</u>
The Contract Time will be (increased) (decreased) (unchanged) by	(107) days
The date of Substantial Completion as of the date of this Change Order therefore is	January 18, 2017.

(Note: This Change Order does not include changes in the Contract Sum, Contract Time or Guaranteed Maximum Price Which have been authorized by Construction Change Directive until the cost and time have been agreed upon by both the Owner and Contractor, in which case a Change Order is executed to supersede the Construction Change Directive.)

NOT VALID UNTIL SIGNED BY THE ARCHITECT, CONTRACTOR AND OWNER.

SEPULVEDA ASSOCIATES

ARCHITECTS, INC.
ARCHITECT (Firm name)

1820 HOUSTON ST. STE A
ADDRESS

BY (Signature)

ROBERTO J. SEPULVEDA, AIA

(Typed name)

DATE

ABBA CONSTRUCTION, LLC
CONTRACTOR (Firm name)

201 W. Hillside Rd. Ste. 6
ADDRESS

BY (Signature)

JACOB FLORES

(Typed name)

DATE

CITY OF LAREDO
OWNER (Firm name)

1110 HOUSTON ST.
ADDRESS

BY (Signature)

Roselio Rivera

(Typed name)

DATE

CAUTION: You should sign an original AIA Contract Document, on which this text appears RED. An original assures that changes will not be obscured.

Date: 2-01-17

To: Mr. Rogelio Rivera, P.E., City Engineer, City of Laredo, 1110 Houston St. Laredo, Texas 78040

RE: TIME DELAY LETTER FOR EL METRO M/O ROOF REPLACEMENT PROJECT

Dear Mr. Rivera,

As per your request, below please find the TIME DELAY JUSTIFICATION for EL METRO ROOF REPLACEMENT PROJECT. Attached, also find the letter form MBCI explaining the manufacturing & delivery delay justifications on the project.

IMPORTANT DATES

1. Original Contract Commencement Time: May 9th 2016
2. Completion Date: October 5th 2016
3. Substantial Completion & Final Walk-through: December 20th 2016
4. Time Extension: January 5th 2016. See Attached Justification Letter from MBCI.
5. MBCI Final Inspection Date: January 10, 2017. See Attached Email from MBCI.
6. MBCI Lead Time Review Process to Issue Letter of Substantial Completion: January 10 through January 18, 2017.
7. MBCI Tentative Issue of Warranty Documents: February 10, 2017.
8. MBCI Issue of Warranty Documents: Week of February 6, 2017.

SEQUENCE OF EVENTS

FOR EL METRO M/O ROOF REPLACEMENT BUILDING IMPROVEMENTS PROJECT

According to the National Weather Forecast, inclement weather records show that we had approximately 73 days of bad weather in Laredo, Texas. The attached calendar includes rain days, wet days, wind days, and holidays that occurred during the course of the project. Please see attached file.

Beginning on May 18th through July 11th, the submittal process took approximately 59 days.

We also encountered owner delays between May 18th and early August, since the owner requested no work activity until all the materials would be available on site.

Other delays which interfere with the construction schedule were the ordering of the restroom lockers for the Operations Building. The manufacturing and delivery lead time took 12 weeks. The same happened with the ordering of floor tile. According to the manufacturer/supplier, the floor tile was a special order. Therefore, the lead time to manufacture and deliver the special order floor tile took approximately six weeks.

The color selection on the roof panels also took well over a month. We requested it on May 18th and did not get an answer until July the 11th.

Two additional factors which also caused further delays to the construction schedule were CEA #1: Canopy Modifications and CEA #2: Full Replacement of the Restroom Floor Tile. CEA #1 which included the execution of a new reinforce concrete footing design and the ordering of floor tile, took well over 35 days.

The change in scope of the roof panels also contributed to more delays. The process of redesigning a splice on the roof panels, obtaining approval and receiving the appropriate repair parts, took approximately 25 days.

We also had another delay regarding a change in scope on the Operations Building: The purlin spacing was less than the design spacing. This modification required that we order additional roof supports or "ROOF HUGGERS" to properly install the Insulated Metal Panels on the Operations Building. The design modifications on the roof, in conjunction with the manufacturing and delivery of the roof huggers, took approximately 30 days.

One other factor that caused significant delays was extra lead time on delivery of MBCI products. According to their corporate office, one of their manufacturing plant facilities burned down.

Finally, the MBCI inspection and warranty process also contributed to additional delays. We, on the other hand, are proud to have delivered the City of Laredo a weather-tight aesthetically appealing roof system for EL METRO at the MAINTENANCE & OPERATIONS FACILITIES.

As a token of our appreciation for your patience, understanding and cooperation, we added to the project, at no cost to the City of Laredo, one Aluminum Curb and one Roof Canopy Retrofit System at the Maintenance Building. The total cost is estimated at \$25,000.

Nonetheless we were informed by MBCI that the additional materials "ROOF HUGGERS" required to properly anchor the clips for the INSULATED METAL PANEL RETROFIT on the Operations building were not part of the scope, since the joist spacing was shorted than the plans showed. Therefore, they are requesting reimbursement for the additional the additional order of ROOF HUGGERS. Please see attached invoice.

We are open to suggestions and to how we can resolve this issue with our supplier.

If you have any questions, please feel free to contact me at any time.

Respectfully Submitted,

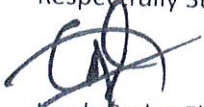

Jacob Carlos Flores

President

ABBA CONSTRUCTION, LLC



December 28, 2016

Abba Construction
PO Box 451441
Laredo, Texas 78045
Attn: Carlos Flores

RE: El Metro Maintenance and Ops Buildings

Dear Mr. Flores,

As you are aware MBCI or Metl Span did lose the capacity of a full producing plant with the loss due to fire of the Jackson MS plant in June of this year. We have continued to struggle to regain schedules thereafter. Thus causing some delays in delivery of insulated panels.

Feel free to call me if you have any questions.

Sincerely,

A handwritten signature in black ink that reads "Jay Greathouse". The signature is written in a cursive style with a large, stylized initial "J".

Jay Greathouse
Project Manager
MBCI San Antonio, Texas

Project Management Department



San Antonio Office

January 18, 2017

ABBA Construction, LLC
P.O. Box 451441
Laredo, Texas 78045

RE: El Metro Maintenance & Operation Buildings
WTW# - 25947-04-15 & 25948-04-15

Dear Mr. Carlos Flores

As of January 16, 2017 all deficiencies and repairs have been approved for both buildings. Please find attach two "Date of Substantial Completion forms". Please submit with the correct name of project, address and date of completion to start the issuing process of the weathertight warranty. Prior to issuance all seamers & crimpers must be returned and all invoices pertaining to these projects must be paid in full.

Sincerely,

A handwritten signature in cursive script that reads "Diane Gonzales".

Diane Gonzales
Administrative – Project Services



ARCHITECTURAL DETAILS

END LAP DETAIL

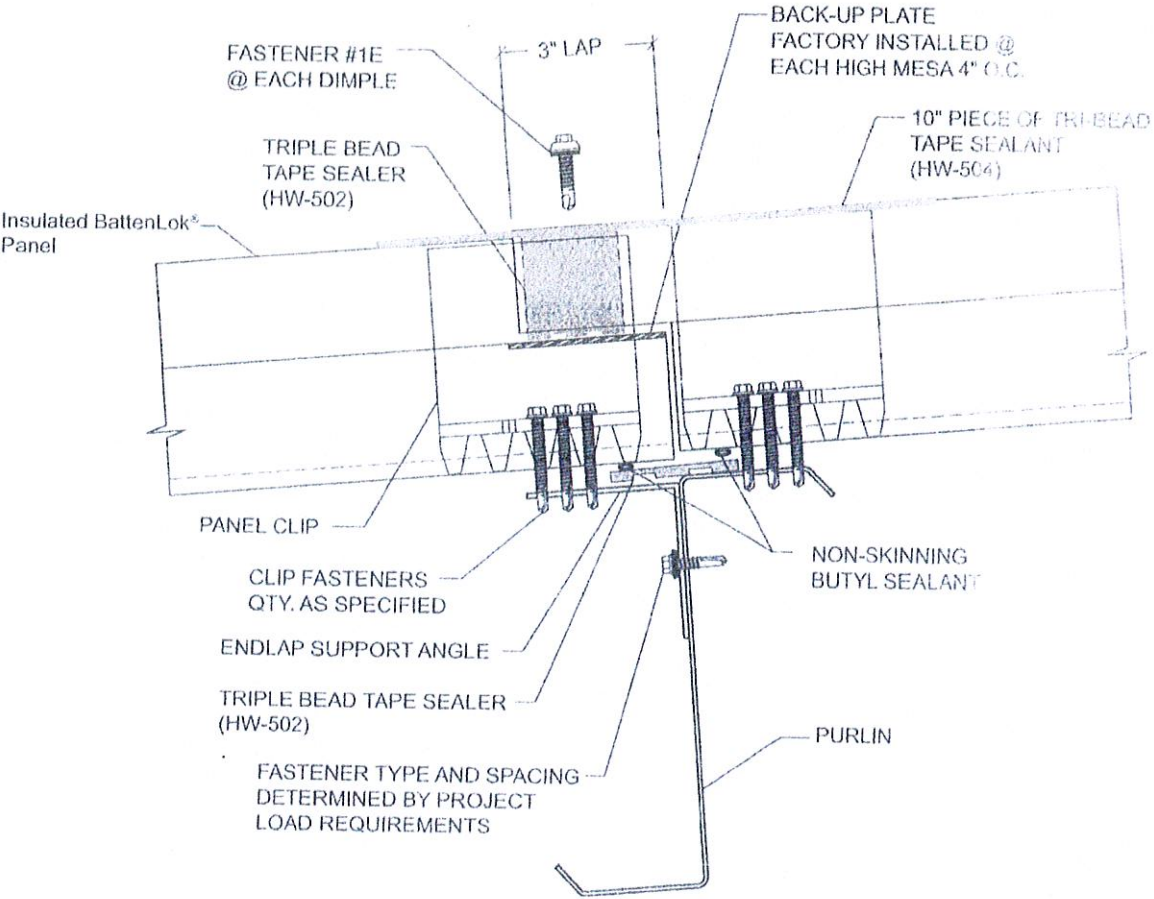

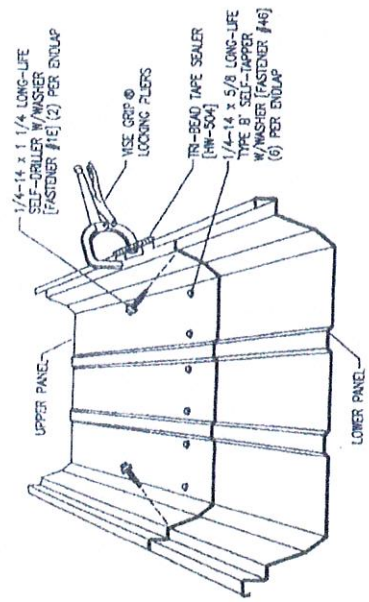
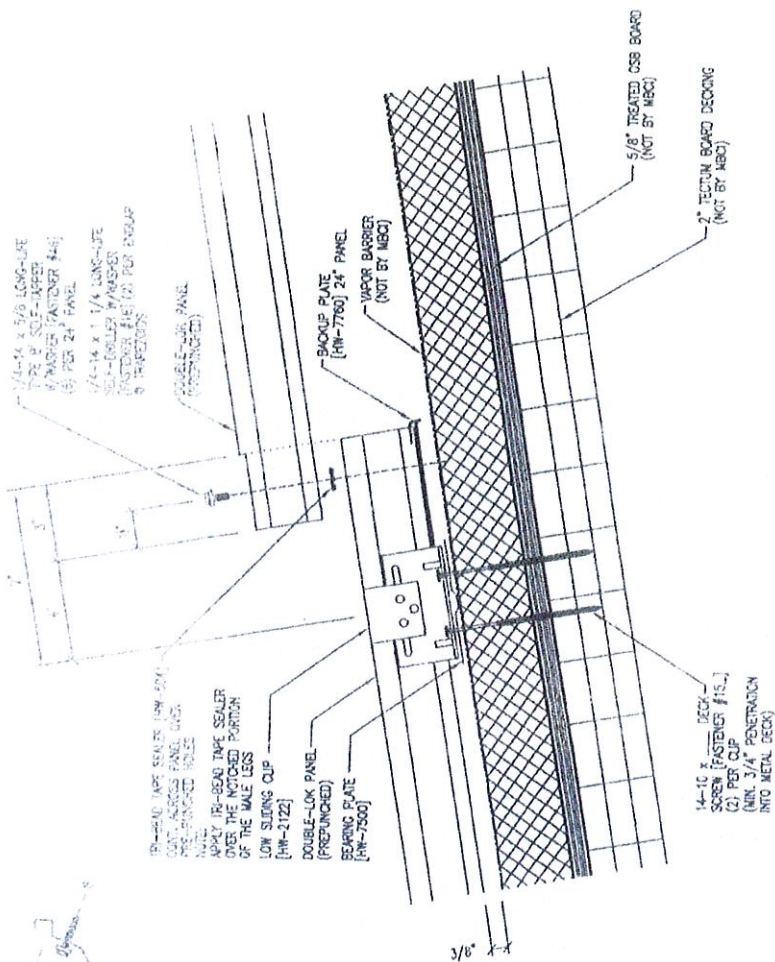
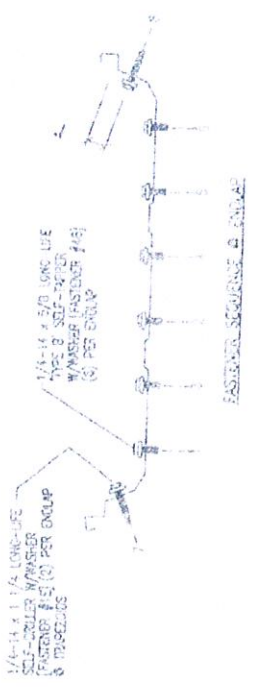

PANEL INSTALLATION SEQUENCE

SECTION W AT DOUBLE-LOK END LAP
 D10



14001 WEST HARDY
HOUSTON, TEXAS 77060
281.744.6333

NO.	DATE	DESCRIPTION	BY	CHKD.
1	02/25/15	ISSUE FOR PERMIT	MM	MM
2	03/27/15	REVISION	MM	MM
3	04/15/15	REVISION	MM	MM
4	04/22/15	REVISION	MM	MM
5	04/22/15	REVISION	MM	MM
6	04/22/15	REVISION	MM	MM
7	04/22/15	REVISION	MM	MM
8	04/22/15	REVISION	MM	MM
9	04/22/15	REVISION	MM	MM
10	04/22/15	REVISION	MM	MM

PROJECT: **El Metro Maint. & Ops Bldg.**
 CONTRACTOR: **Alba Construction**
 ARCHITECT: **Sopriveda Associates Architects**
 QUOTE NUMBER: **04-1379-15**

PROJECT: **El Metro Maint. & Ops Bldg.**

DRAWING NUMBER: **E2**



KEY PLAN
PERFORMING BASELINE

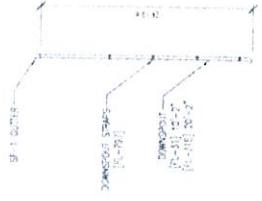

DOWNSPOUT W/ 45° KICKOUT
NOT TO SCALE

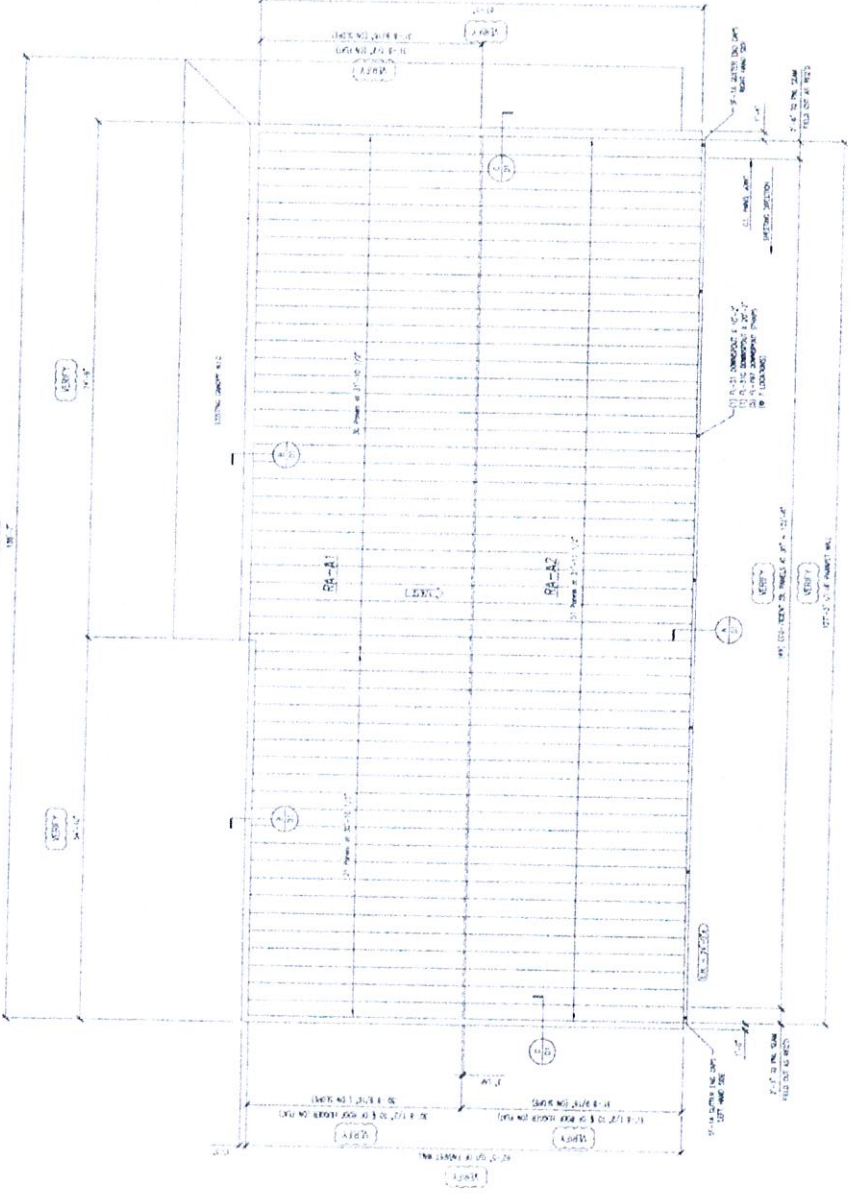

ROOF PANEL LAYOUT OPERATIONS BUILDING (BY 12)

NOT TO SCALE
OPERATIONS BUILDING (BY 12)

NOT TO SCALE
OPERATIONS BUILDING (BY 12)

ALBA CONSTRUCTION
14001 WEST HARDY
HOUSTON, TEXAS 77060
281.744.6333

Laredo, TX



















Laredo International

© 4:57 PM CST on January 31, 2017 [GMT -0600]













11 Days

 Today  Forecast

Weather History for KLRD - May, 2016

Sunday	Monday	Tuesday	Wednesday	Thursday	Friday	Saturday
1  Actual: 95° 73° 0.00 in Average: 91° 68° 0.07 in	2  Actual: 76° 64° T in Average: 91° 69° 0.07 in	3  Actual: 83° 63° 0.00 in Average: 91° 69° 0.07 in	4  Actual: 90° 60° 0.00 in Average: 91° 69° 0.08 in	5  Actual: 95° 63° 0.00 in Average: 91° 69° 0.08 in	6  Actual: 96° 65° 0.00 in Average: 92° 69° 0.08 in	7  Actual: 93° 67° 0.00 in Average: 92° 70° 0.09 in
8  Actual: 90° 72° 0.06 in Average: 92° 70° 0.08 in	9  Actual: 95° 70° 0.37 in Average: 92° 70° 0.08 in	10  Actual: 100° 73° 0.00 in Average: 92° 70° 0.08 in	11  Actual: 94° 76° 0.00 in Average: 92° 71° 0.08 in	12  Actual: 91° 73° 0.00 in Average: 92° 71° 0.08 in	13  Actual: 96° 73° 0.00 in Average: 93° 71° 0.08 in	14  Actual: 80° 68° 0.44 in Average: 93° 71° 0.09 in
15  Actual: 80° 70° T in Average: 93° 71° 0.08 in	16  Actual: 92° 67° 0.37 in Average: 94° 72° 0.08 in	17  Actual: 97° 71° 0.01 in Average: 94° 72° 0.09 in	18  Actual: 83° 69° 0.29 in Average: 94° 72° 0.08 in	19  Actual: 78° 66° 0.75 in Average: 94° 72° 0.08 in	20 Actual: 78° 66° T in Average: 94° 72° 0.08 in	21 Actual: 93° 75° T in Average: 95° 73° 0.08 in
22 Actual: 90° 76° 0.00 in Average: 95° 73° 0.07 in	23 Actual: 95° 75° 0.00 in Average: 95° 73° 0.08 in	24 Actual: 92° 77° T in Average: 95° 73° 0.08 in	25 Actual: 94° 79° T in Average: 95° 73° 0.08 in	26 Actual: 96° 77° 0.00 in Average: 96° 74° 0.08 in	27 Actual: 102° 77° 0.00 in Average: 96° 74° 0.08 in	28 Actual: 97° 78° 0.00 in Average: 96° 74° 0.09 in
29 Actual: 95° 78° 0.00 in Average: 96° 74° 0.08 in	30 Actual: 90° 74° 0.00 in Average: 96° 74° 0.09 in	31 Actual: 96° 72° 0.41 in Average: 97° 74° 0.08 in				

Calendar Legend

-  Sunny Clear
-  Mostly Cloudy
-  Partly Cloudy
-  Cloudy
-  Rain
-  Snow
-  Hail Flurries
-  Thunderstorms
-  Hazy Fog
-  Sleet
-  '?' denotes 'chance of'
-  Unknown

Laredo, TX





























































Laredo International

© 4:57 PM CST on January 31, 2017 [GMT -0600]

 Today  Forecast

Weather History for KLRD June, 2016

8 Days

Sunday	Monday	Tuesday	Wednesday	Thursday	Friday	Saturday
			  Actual: 86° 70° 0.05 in Average: 97° 74° 0.07 in	  Actual: 90° 67° 0.79 in Average: 97° 75° 0.06 in	  Actual: 91° 69° T in Average: 97° 75° 0.07 in	  Actual: 90° 69° T in Average: 97° 75° 0.07 in
  Actual: 91° 70° 0.00 in Average: 97° 75° 0.07 in	  Actual: 92° 66° 0.00 in Average: 97° 75° 0.08 in	  Actual: 94° 69° 0.00 in Average: 98° 75° 0.07 in	  Actual: 95° 73° 0.00 in Average: 98° 75° 0.08 in	  Actual: 96° 73° 0.00 in Average: 98° 76° 0.07 in	  Actual: 98° 75° 0.00 in Average: 98° 76° 0.07 in	  Actual: 96° 78° 0.00 in Average: 98° 76° 0.07 in
  Actual: 100° 79° 0.00 in Average: 98° 76° 0.06 in	  Actual: 102° 79° 0.00 in Average: 98° 76° 0.07 in	  Actual: 103° 79° 0.00 in Average: 98° 76° 0.07 in	  Actual: 104° 78° 0.00 in Average: 98° 76° 0.07 in	  Actual: 103° 79° 0.00 in Average: 98° 76° 0.07 in	  Actual: 103° 76° 0.00 in Average: 98° 76° 0.07 in	  Actual: 104° 78° 0.00 in Average: 99° 76° 0.07 in
  Actual: 100° 77° 0.05 in Average: 99° 76° 0.09 in	  Actual: 96° 75° T in Average: 99° 76° 0.08 in	  Actual: 99° 73° 0.00 in Average: 99° 76° 0.08 in	  Actual: 102° 76° 0.00 in Average: 99° 77° 0.09 in	  Actual: 100° 75° 0.00 in Average: 99° 77° 0.08 in	  Actual: 102° 76° 0.00 in Average: 99° 77° 0.09 in	  Actual: 98° 80° 0.01 in Average: 99° 77° 0.08 in
  Actual: 100° 79° 0.00 in Average: 99° 77° 0.08 in	  Actual: 100° 77° 0.00 in Average: 99° 77° 0.08 in	  Actual: 103° 72° 1.02 in Average: 99° 77° 0.08 in	  Actual: 96° 74° T in Average: 99° 77° 0.07 in	  Actual: 100° 78° 0.00 in Average: 99° 77° 0.07 in		

Calendar Legend

-  Sunny Clear
-  Mostly Cloudy
-  Partly Cloudy
-  Cloudy
-  Rain
-  Snow
-  Hail Flurries
-  Thunderstorms
-  Hazy Fog
-  Sleet
-  '?' denotes 'chance of'
-  Unknown































Laredo, TX 🏠

Laredo International







© 4:57 PM CST on January 31, 2017 [GMT -0600]

☐ Today ☐ Forecast

Weather History for KLRD July 2016

Sunday	Monday	Tuesday	Wednesday	Thursday	Friday	Saturday
					1	2
			6 Days		 Actual: 102° 77° 0.00 in Average: 99° 77° 0.09 in	 Actual: 102° 78° 0.00 in Average: 99° 77° 0.08 in
3	4	5	6	7	8	9
 Actual: 106° 81° 0.00 in Average: 99° 77° 0.08 in	 Actual: 107° 79° 0.00 in Average: 99° 77° 0.08 in	 Actual: 105° 80° 0.00 in Average: 99° 77° 0.07 in	 Actual: 104° 80° 0.00 in Average: 99° 77° 0.08 in	 Actual: 105° 79° 0.00 in Average: 99° 77° 0.08 in	 Actual: 103° 79° 0.00 in Average: 99° 77° 0.08 in	 Actual: 105° 80° 0.00 in Average: 99° 77° 0.07 in
10	11	12	13	14	15	16
 Actual: 102° 81° 0.00 in Average: 99° 77° 0.09 in	 Actual: 105° 80° 0.00 in Average: 99° 77° 0.08 in	 Actual: 103° 78° 0.00 in Average: 99° 77° 0.08 in	 Actual: 105° 79° 0.00 in Average: 99° 77° 0.08 in	 Actual: 107° 80° 0.00 in Average: 99° 77° 0.08 in	 Actual: 107° 79° 0.00 in Average: 99° 77° 0.07 in	 Actual: 103° 77° 0.00 in Average: 99° 77° 0.07 in
17	18	19	20	21	22	23
 Actual: 103° 77° 0.00 in Average: 99° 77° 0.06 in	 Actual: 104° 78° 0.00 in Average: 99° 77° 0.06 in	 Actual: 100° 77° 0.04 in Average: 99° 77° 0.06 in	 Actual: 102° 76° 0.00 in Average: 99° 77° 0.06 in	 Actual: 102° 75° 0.00 in Average: 100° 77° 0.05 in	 Actual: 103° 76° 0.00 in Average: 100° 77° 0.05 in	 Actual: 105° 77° 0.00 in Average: 100° 77° 0.05 in
24	25	26	27	28	29	30
 Actual: 105° 79° 0.00 in Average: 100° 77° 0.05 in	 Actual: 104° 79° 0.00 in Average: 100° 77° 0.04 in	 Actual: 96° 76° 0.13 in Average: 100° 77° 0.05 in	 Actual: 96° 77° 0.06 in Average: 100° 77° 0.05 in	 Actual: 102° 74° 0.03 in Average: 100° 77° 0.04 in	 Actual: 101° 73° 1.03 in Average: 100° 77° 0.05 in	 Actual: 102° 74° 0.05 in Average: 100° 77° 0.04 in
31						
 Actual: 102° 77° 0.00 in Average: 100° 77° 0.04 in						

Calendar Legend

-  Sunny Clear
-  Mostly Cloudy
-  Partly Cloudy
-  Cloudy
-  Rain
-  Snow

Laredo, TX































Laredo International

© 4:57 PM CST on January 31, 2017 (GMT -0600)

6 Days

Today Forecast

Weather History for KLRD - August, 2016

Sunday	Monday	Tuesday	Wednesday	Thursday	Friday	Saturday
	1 	2 	3 	4 	5 	6 
	Actual: 103° 77° 0.00 in Average: 100° 77° 0.04 in	Actual: 103° 77° 0.00 in Average: 101° 77° 0.03 in	Actual: 102° 77° 0.00 in Average: 101° 77° 0.04 in	Actual: 103° 77° 0.00 in Average: 101° 77° 0.03 in	Actual: 103° 78° 0.00 in Average: 101° 77° 0.03 in	Actual: 104° 79° 0.00 in Average: 101° 77° 0.04 in
7 	8 	9 	10 	11 	12 	13 
Actual: 103° 80° 0.00 in Average: 101° 77° 0.04 in	Actual: 106° 79° 0.00 in Average: 101° 77° 0.03 in	Actual: 106° 80° 0.00 in Average: 101° 77° 0.05 in	Actual: 107° 80° 0.00 in Average: 101° 77° 0.05 in	Actual: 108° 81° 0.00 in Average: 101° 77° 0.04 in	Actual: 108° 80° 0.00 in Average: 101° 77° 0.05 in	Actual: 97° 80° 0.00 in Average: 101° 77° 0.04 in
14 	15 	16 	17 	18 	19 	20 
Actual: 90° 76° 0.65 in Average: 101° 77° 0.05 in	Actual: 89° 75° 0.40 in Average: 101° 77° 0.05 in	Actual: 91° 77° 0.12 in Average: 100° 77° 0.06 in	Actual: 95° 76° 0.02 in Average: 100° 77° 0.06 in	Actual: 98° 75° 0.00 in Average: 100° 77° 0.06 in	Actual: 99° 78° 0.00 in Average: 100° 77° 0.07 in	Actual: 96° 75° 0.54 in Average: 100° 77° 0.07 in
21 	22 	23 	24 	25 	26 	27 
Actual: 88° 73° 1.10 in Average: 100° 77° 0.07 in	Actual: 95° 76° 0.02 in Average: 100° 77° 0.07 in	Actual: 98° 76° 0.00 in Average: 99° 77° 0.08 in	Actual: 99° 77° 0.00 in Average: 99° 77° 0.08 in	Actual: 98° 75° 0.00 in Average: 99° 77° 0.08 in	Actual: 97° 75° 0.00 in Average: 99° 77° 0.09 in	Actual: 98° 75° 0.00 in Average: 99° 77° 0.09 in
28 	29 	30 	31 			
Actual: 96° 76° 0.00 in Average: 98° 77° 0.09 in	Actual: 94° 76° 0.00 in Average: 98° 76° 0.10 in	Actual: 89° 75° 0.46 in Average: 98° 76° 0.10 in	Actual: 95° 74° 0.00 in Average: 98° 76° 0.10 in			

Calendar Legend

-  Sunny Clear
-  Mostly Cloudy
-  Partly Cloudy
-  Cloudy
-  Rain
-  Snow
-  Hail Flurries
-  Thunderstorms
-  Hazy Fog
-  Sleet
-  '?' denotes 'chance of'
-  Unknown































Laredo, TX

Laredo International













© 4:57 PM CST on January 31, 2017 [GMT -0600]

 Today  Forecast

Weather History for KLRD - September, 2016

Sunday	Monday	Tuesday	Wednesday	Thursday	Friday	Saturday
				1 	2 	3 
			<i>(9) Pops</i>	Actual: 92° 76° 0.31 in Average: 97° 76° 0.11 in	Actual: 96° 75° T in Average: 97° 76° 0.11 in	Actual: 95° 74° T in Average: 97° 76° 0.11 in
4 	5 	6 	7 	8 	9 	10 
Actual: 95° 75° 0.01 in Average: 97° 75° 0.11 in	Actual: 97° 75° 0.02 in Average: 96° 75° 0.11 in	Actual: 99° 78° 0.00 in Average: 96° 75° 0.12 in	Actual: 100° 78° 0.00 in Average: 96° 75° 0.10 in	Actual: 100° 76° 0.00 in Average: 95° 75° 0.10 in	Actual: 100° 75° 0.00 in Average: 95° 74° 0.11 in	Actual: 99° 76° T in Average: 95° 74° 0.11 in
11 	12 	13 	14 	15 	16 	17 
Actual: 97° 74° 0.01 in Average: 95° 74° 0.11 in	Actual: 99° 75° 0.00 in Average: 94° 74° 0.11 in	Actual: 100° 77° 0.82 in Average: 94° 73° 0.11 in	Actual: 96° 78° 0.00 in Average: 94° 73° 0.09 in	Actual: 96° 76° T in Average: 93° 73° 0.10 in	Actual: 99° 76° 0.00 in Average: 93° 73° 0.10 in	Actual: 100° 78° 0.00 in Average: 89° 71° 0.17 in
18 	19 	20 	21 	22 	23 	24 
Actual: 102° 78° 0.00 in Average: 93° 72° 0.09 in	Actual: 103° 78° 0.00 in Average: 92° 72° 0.09 in	Actual: 101° 76° 0.00 in Average: 92° 72° 0.08 in	Actual: 99° 76° 0.00 in Average: 92° 71° 0.09 in	Actual: 97° 72° 0.00 in Average: 92° 71° 0.08 in	Actual: 100° 77° 0.00 in Average: 91° 71° 0.09 in	Actual: 100° 78° 0.00 in Average: 91° 71° 0.08 in
25 	26 	27 	28 	29 	30 	
Actual: 99° 71° 3.47 in Average: 91° 70° 0.09 in	Actual: 86° 69° 0.41 in Average: 91° 70° 0.09 in	Actual: 75° 67° T in Average: 91° 70° 0.09 in	Actual: 89° 68° 0.00 in Average: 90° 70° 0.09 in	Actual: 93° 71° 0.00 in Average: 90° 69° 0.08 in	Actual: 84° 64° 0.00 in Average: 90° 69° 0.09 in	

Calendar Legend

-  Sunny Clear
-  Mostly Cloudy
-  Partly Cloudy
-  Cloudy
-  Rain
-  Snow
-  Hail Flurries
-  Thunderstorms
-  Hazy Fog
-  Sleet
-  '?' denotes 'chance of'
-  Unknown































Laredo, TX

Laredo International

© 4:58 PM CST on January 31, 2017 [GMT -0600]

 Today  Forecast

Weather History for KLRD - October, 2016

Sunday	Monday	Tuesday	Wednesday	Thursday	Friday	Saturday
						1  Actual: 82° 66° 0.00 in Average: 90° 69° 0.09 in
2  Actual: 87° 70° 0.00 in Average: 89° 69° 0.08 in	3  Actual: 92° 68° 0.00 in Average: 89° 68° 0.08 in	4  Actual: 96° 73° 0.00 in Average: 89° 68° 0.08 in	5  Actual: 98° 75° 0.00 in Average: 89° 68° 0.08 in	6  Actual: 96° 75° 0.00 in Average: 89° 68° 0.08 in	7  Actual: 94° 75° 0.01 in Average: 88° 68° 0.08 in	8  Actual: 87° 65° T in Average: 88° 67° 0.08 in
9  Actual: 88° 67° 0.00 in Average: 88° 67° 0.09 in	10  Actual: 89° 59° 0.00 in Average: 88° 67° 0.08 in	11  Actual: 91° 63° 0.00 in Average: 88° 67° 0.08 in	12  Actual: 94° 69° 0.00 in Average: 87° 66° 0.08 in	13  Actual: 96° 75° 0.00 in Average: 87° 66° 0.08 in	14  Actual: 95° 73° 0.00 in Average: 87° 66° 0.07 in	15  Actual: 94° 73° 0.00 in Average: 87° 66° 0.08 in
16  Actual: 94° 73° 0.00 in Average: 87° 65° 0.08 in	17  Actual: 95° 73° 0.00 in Average: 86° 65° 0.08 in	18  Actual: 97° 74° 0.00 in Average: 86° 65° 0.08 in	19  Actual: 96° 75° 0.00 in Average: 86° 65° 0.07 in	20  Actual: 93° 68° 0.07 in Average: 86° 64° 0.08 in	21  Actual: 79° 61° 0.00 in Average: 85° 64° 0.07 in	22  Actual: 84° 53° 0.00 in Average: 85° 64° 0.06 in
23  Actual: 87° 63° 0.00 in Average: 85° 64° 0.07 in	24  Actual: 90° 70° 0.00 in Average: 84° 63° 0.06 in	25  Actual: 89° 68° 0.00 in Average: 84° 63° 0.06 in	26  Actual: 91° 66° 0.00 in Average: 84° 63° 0.05 in	27  Actual: 90° 68° 0.00 in Average: 84° 62° 0.05 in	28  Actual: 88° 62° 0.00 in Average: 83° 62° 0.05 in	29  Actual: 91° 65° 0.00 in Average: 83° 62° 0.05 in
30  Actual: 90° 67° 0.00 in Average: 83° 61° 0.04 in	31  Actual: 91° 67° 0.00 in Average: 82° 61° 0.05 in					

3 Days

Calendar Legend

-  Sunny Clear
-  Mostly Cloudy
-  Partly Cloudy
-  Cloudy
-  Rain
-  Snow

Laredo, TX

Laredo International































© 4:58 PM CST on January 31, 2017 [GMT -0600]

8 Days

 Today

 Forecast

Weather History for KLRD - November, 2016

Sunday	Monday	Tuesday	Wednesday	Thursday	Friday	Saturday
		1 	2 	3 	4 	5 
		Actual: 93° 72° 0.00 in Average: 82° 61° 0.05 in	Actual: 92° 77° 0.00 in Average: 82° 60° 0.05 in	Actual: 91° 74° 0.07 in Average: 81° 60° 0.05 in	Actual: 78° 71° 0.02 in Average: 81° 60° 0.06 in	Actual: 85° 69° 0.00 in Average: 80° 59° 0.04 in
6 	7 	8 	9 	10 	11 	12 
Actual: 85° 71° T in Average: 80° 59° 0.05 in	Actual: 89° 71° 0.00 in Average: 80° 59° 0.04 in	Actual: 73° 66° 0.38 in Average: 79° 58° 0.04 in	Actual: 68° 63° 0.20 in Average: 79° 58° 0.04 in	Actual: 73° 64° T in Average: 78° 57° 0.05 in	Actual: 74° 61° T in Average: 78° 57° 0.04 in	Actual: 74° 62° T in Average: 78° 57° 0.03 in
13 	14 	15 	16 	17 	18 	19 
Actual: 74° 62° T in Average: 77° 56° 0.04 in	Actual: 81° 60° 0.00 in Average: 77° 56° 0.04 in	Actual: 86° 56° 0.00 in Average: 76° 55° 0.04 in	Actual: 87° 55° 0.00 in Average: 76° 55° 0.04 in	Actual: 88° 63° 0.00 in Average: 76° 55° 0.04 in	Actual: 85° 65° 0.00 in Average: 75° 54° 0.04 in	Actual: 67° 48° 0.00 in Average: 75° 54° 0.04 in
20 	21 	22 	23 	24 	25 	26 
Actual: 72° 42° 0.00 in Average: 75° 53° 0.03 in	Actual: 82° 51° 0.00 in Average: 74° 53° 0.04 in	Actual: 84° 67° 0.00 in Average: 74° 53° 0.03 in	Actual: 80° 61° 0.00 in Average: 73° 52° 0.04 in	Actual: 80° 57° 0.00 in Average: 73° 52° 0.03 in	Actual: 84° 60° 0.00 in Average: 73° 52° 0.04 in	Actual: 74° 62° 0.00 in Average: 72° 51° 0.03 in
27 	28 	29 	30 			
Actual: 84° 65° 0.00 in Average: 72° 51° 0.03 in	Actual: 87° 62° 0.00 in Average: 72° 51° 0.04 in	Actual: 83° 54° 0.00 in Average: 71° 50° 0.03 in	Actual: 75° 51° 0.00 in Average: 71° 50° 0.03 in			

Calendar Legend

-  Sunny Clear
-  Mostly Cloudy
-  Partly Cloudy
-  Cloudy
-  Rain
-  Snow
-  Hail Flurries
-  Thunderstorms
-  Hazy Fog
-  Sleet
-  ?' denotes 'chance of'
-  Unknown

Laredo, TX

Laredo International































© 4:58 PM CST on January 31, 2017 [GMT -0600]

13 Rain













 Today

 Forecast

Weather History for KLRD - December, 2016

Sunday	Monday	Tuesday	Wednesday	Thursday	Friday	Saturday
				1 	2 	3 
				Actual: 77° 48° 0.00 in	Actual: 77° 65° 0.23 in	Actual: 68° 56° 0.17 in
				Average: 71° 50° 0.03 in	Average: 70° 49° 0.03 in	Average: 70° 49° 0.02 in
4 	5 	6 	7 	8 	9 	10 
Actual: 57° 54° 0.98 in	Actual: 67° 51° 0.03 in	Actual: 81° 45° 0.00 in	Actual: 65° 50° T in	Actual: 56° 43° 0.08 in	Actual: 48° 41° 0.00 in	Actual: 49° 44° 0.03 in
Average: 70° 49° 0.03 in	Average: 70° 49° 0.02 in	Average: 69° 48° 0.02 in	Average: 69° 48° 0.02 in	Average: 69° 48° 0.02 in	Average: 69° 48° 0.03 in	Average: 68° 47° 0.03 in
11 	12 	13 	14 	15 	16 	17 
Actual: 60° 48° 0.04 in	Actual: 61° 57° 0.01 in	Actual: 62° 59° 0.01 in	Actual: 66° 54° 0.00 in	Actual: 63° 58° 0.00 in	Actual: 69° 55° T in	Actual: 85° 66° 0.00 in
Average: 68° 47° 0.02 in	Average: 68° 47° 0.03 in	Average: 68° 47° 0.03 in	Average: 68° 47° 0.03 in	Average: 68° 47° 0.03 in	Average: 67° 46° 0.02 in	Average: 67° 46° 0.03 in
18 	19 	20 	21 	22 	23 	24 
Actual: 73° 35° 0.00 in	Actual: 45° 32° 0.00 in	Actual: 61° 44° 0.00 in	Actual: 72° 45° 0.00 in	Actual: 62° 57° 0.04 in	Actual: 73° 58° 0.02 in	Actual: 82° 61° 0.00 in
Average: 67° 46° 0.03 in	Average: 67° 46° 0.03 in	Average: 67° 46° 0.03 in	Average: 67° 46° 0.03 in	Average: 67° 46° 0.03 in	Average: 67° 46° 0.03 in	Average: 66° 46° 0.03 in
25 	26 	27 	28 	29 	30 	31 
Actual: 87° 69° 0.00 in	Actual: 82° 66° 0.00 in	Actual: 83° 63° T in	Actual: 79° 65° 0.00 in	Actual: 72° 58° 0.00 in	Actual: 68° 52° 0.00 in	Actual: 74° 58° T in
Average: 66° 46° 0.04 in	Average: 66° 46° 0.03 in	Average: 66° 46° 0.03 in	Average: 66° 46° 0.03 in	Average: 66° 46° 0.04 in	Average: 66° 45° 0.03 in	Average: 66° 45° 0.03 in

Calendar Legend

-  Sunny Clear
-  Mostly Cloudy
-  Partly Cloudy
-  Cloudy
-  Rain
-  Snow
-  Hail Flurries
-  Thunderstorms
-  Hazy Fog
-  Sleet
-  '?' denotes 'chance of'
-  Unknown

Laredo, TX































Laredo International

© 4:58 PM CST on January 31, 2017 [GMT -0600]















Today Forecast

Weather History for KLRD January, 2017

Sunday	Monday	Tuesday	Wednesday	Thursday	Friday	Saturday
1  Actual: 81° 60° 0.00 in Average: 67° 45° 0.04 in	2  Actual: 82° 57° 0.00 in Average: 67° 45° 0.04 in	3  Actual: 82° 51° 0.00 in Average: 67° 45° 0.04 in	4  Actual: 65° 47° 0.00 in Average: 66° 45° 0.03 in	5  Actual: 75° 56° 0.00 in Average: 66° 45° 0.03 in	6  Actual: 57° 32° T in Average: 66° 46° 0.03 in	7  Actual: 47° 27° 0.00 in Average: 66° 46° 0.03 in
8  Actual: 58° 25° 0.00 in Average: 66° 46° 0.03 in	9  Actual: 75° 37° 0.00 in Average: 66° 46° 0.03 in	10  Actual: 83° 57° 0.00 in Average: 66° 46° 0.03 in	11  Actual: 87° 60° 0.00 in Average: 66° 46° 0.02 in	12  Actual: 86° 63° 0.00 in Average: 66° 46° 0.03 in	13  Actual: 83° 66° T in Average: 67° 46° 0.03 in	14  Actual: 81° 67° T in Average: 67° 46° 0.03 in
15  Actual: 84° 67° T in Average: 67° 46° 0.03 in	16  Actual: 75° 66° 0.00 in Average: 67° 46° 0.03 in	17  Actual: 76° 58° 0.01 in Average: 67° 46° 0.02 in	18  Actual: 67° 52° T in Average: 67° 46° 0.03 in	19  Actual: 82° 56° 0.00 in Average: 67° 46° 0.03 in	20  Actual: 75° 59° T in Average: 67° 46° 0.03 in	21  Actual: 94° 54° 0.00 in Average: 67° 46° 0.03 in
22  Actual: 77° 47° 0.00 in Average: 68° 46° 0.03 in	23  Actual: 84° 43° 0.00 in Average: 68° 47° 0.03 in	24  Actual: 94° 58° 0.00 in Average: 68° 47° 0.03 in	25  Actual: 77° 52° 0.00 in Average: 68° 47° 0.03 in	26  Actual: 70° 42° 0.00 in Average: 68° 47° 0.03 in	27  Actual: 64° 44° T in Average: 68° 47° 0.03 in	28  Actual: 58° 43° T in Average: 68° 47° 0.03 in
29  Actual: 72° 39° 0.00 in Average: 69° 47° 0.03 in	30  Actual: 79° 42° 0.00 in Average: 69° 47° 0.02 in	31  Forecast: 82° 57° 0.0 in Average: 66° 47° 0.06 in				

alendar Legend

-  Sunny Clear
-  Mostly Cloudy
-  Partly Cloudy
-  Cloudy
-  Rain
-  Snow
-  Hail Flurries
-  Thunderstorms
-  Hazy Fog
-  Sleet
-  '?' denotes 'chance of'
-  Unknown

CITY OF LAREDO
CITY OF LAREDO ENGINEERING DEPARTMENT
1110 HOUSTON STREET LAREDO, TEXAS 78040

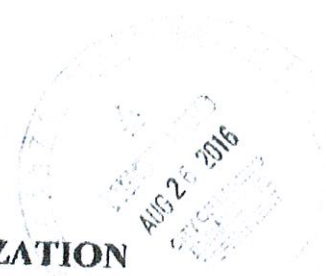

CONTINGENCY ALLOWANCE EXPENDITURE AUTHORIZATION
EL METRO ROOF REPLACEMENT AND RESTROOM IMPROVEMENTS
AUTHORIZATION NO. 1

Contractor: ABBA Construction, LLC Architect: Sepulveda Associates Architects, Inc.
 P.O. BOX 451441 1820 Houston Street
 Laredo, Texas 78045 Laredo, Texas 78040
 956-324-9343 956-725-1985

ABBA Construction, Inc. is hereby authorized to perform the following scope of work and adjust the allowance sum accordingly, as indicated below. *This is not a change order and does not modify the contract amount.*

The following items are herein accepted by the City of Laredo: Item 1, per below.

NO.	DESCRIPTION	STARTING BAL.	PROPOSED COST	ENDING BAL.
	CONTINGENCY ALLOWANCE	\$40,000.00		\$40,000.00
1.	Maintenance Building Structural Canopy Modifications		\$25,473.25	\$14,526.75
2				
3				
	BAL. CONTINGENCY ALLOWANCE			\$14,526.75

ORIGINAL CONTRACT SUM:	\$949,790.00
NET CHANGE BY PREVIOUS CHANGE ORDERS	\$ 0.00
THE CONTRACT SUM	\$949,790.00

 Eduardo Romero, P.E., Project Engineer
 Sierra Consultants

8/24/16
 Date

 Jacob C. Flores, President
 ABBA Construction, Inc.

8/24/16
 Date

 Joe Jackson, Asst. General Manager of Maintenance
 Laredo Transit Management, Inc.

8-24-16
 Date

 Rogelio Rivera, P.E., City Engineer
 City of Laredo Engineering Department

8/29/16
 Date

See Attachments.

PROJECT: Re-Bid City Of Laredo El Metro Operations & Maintenance
Roof Replacement & Building Improvements

Bid Alternates

Add Alternate No. 1 South Canopy At El Metro Maintenance Building
Per Section 01030.....\$ 69,995.⁵²

In Words Sixty Nine Thousand Nine Hundred Ninty Five

Add Alternate No. 2 Restroom Remodeling
Per Section 01030\$ 131,800.⁰⁰

In Words One Hundred Thirty One Thousand Eight Hundred

Unit Pricing

Item No. 1 Tectum Board Replacement.....\$ 6.⁹⁰ /SF

Provide the Owner with a cost for materials and labor for adding or deleting new 2" thick Tectum Board decking and joint grouting over the existing steel "Tee Bulbs" per specs and drawings. Include the removal and disposal of the existing tectum board deck over the steel bar joists. **NOTE: BASE BID must include the new 2" thick Tectum deck board over the existing steel "Tee Bulbs" for the entire roof per drawings.**

In Words Six and ⁹⁰/₁₀₀ Dollars

Item No. 2 Eave Galvanized Steel Angle.....\$ 10.⁰⁰ /LF

Provide the Owner with a cost for materials and labor for adding or deleting the new eave galvanized steel angle as shown on the drawings for the Maintenance Facility Building. Include the removal and disposal of the damaged perimeter steel angle in this unit pricing. **NOTE: BASE BID must include the allowance of 100 LF of new eave galvanized steel angle at perimeter in place for possible replacement if damaged per drawings.**

100 LF
x \$10/LF
\$1,000.00 ✓
CREDIT

In Words Ten Dollars

STATEMENT OF MATERIALS AND OTHER CHARGES

PROJECT: Re-Bid City Of Laredo El Metro Operations & Maintenance
Roof Replacement & Building Improvements

Base Proposal

El Metro – Roof Replacement for Maintenance
And Operations Buildings **Materials Incorporated into the project**:.....\$ 523,596.⁵⁰
All Other Charges (include Allowances) For Base Bid:.....\$ 224,398.⁵⁰
***Total For Base Bid**:.....\$ 747,995.⁰⁰

Add Alternate No. 1

South Canopy At El Metro Maintenance Building
Materials Incorporated Into This Alternate\$ 45,496.⁷⁵
All Other Charges For This Alternate.....\$ 24,498.²⁵
***Total For Add Alternate No. 1**\$ 69,995.⁰⁰

Add Alternate No. 2

Restroom Remodeling **Materials Incorporated Into This Alternate**.....\$ 85,670.⁰⁰
All Other Charges (include Allowances) For This Alternate\$ 46,130.⁰⁰
***Total For Add Alternate No. 2**.....\$ 131,800.⁰⁰

***Base Bid + Alt.#1, + Alt.#2 Total**:.....\$ 949,790.⁰⁰

*This total must agree with the total figure shown in the Item and Quantity Sheets in the bound contract.

For purposes of complying with the Texas Tax Code, the Contractor agrees that the charges for any material incorporated into the project in excess of the estimated quantity provided for herein will be no less than the invoice price for such material to the Contractor.

NOTE: ONLY THE COPY OF THIS FORM IN THE BOUND CONTRACTS IS TO BE FILLED OUT.

Construction contract time for the project is 150 calendar days.

PROJECT: EL METRO OPERATION AND MAINTENANCE BUILDING ROOF REPLACEMENT AND BUILDING IMPROVEMENTS

APPLICATION NUMBER: Six (6) Final
 APPLICATION DATE: 10-Mar-17
 PERIOD FROM: 20-Dec-16
 PERIOD TO: 10-Mar-17

A ITEM NO.	B DESCRIPTION OF WORK	C SCHEDULED VALUE	D WORK COMPLETED		E THIS PERIOD	F MATERIALS STORED (NOT IN D OR E)	G TOTAL COMPLETED AND STORED TO DATE (D + E + F)	H BALANCE TO FINISH (C - G)	I RETAINAGE (IF VARIABLE RATE) 5%
			FROM PREVIOUS APPLICATION (D + E)						
	MOBILIZATION	\$35,000.00	\$35,000.00	\$0.00	\$0.00	\$0.00	\$35,000.00	\$0.00	\$1,750.00
	BONDING COST	\$12,998.00	\$12,998.00	\$0.00	\$0.00	\$0.00	\$12,998.00	\$0.00	\$649.90
	SUPERVISION	\$12,500.00	\$12,500.00	\$0.00	\$0.00	\$0.00	\$12,500.00	\$0.00	\$625.00
	OPERATION BUILDING ROOF LABOR	\$42,000.00	\$42,000.00	\$0.00	\$0.00	\$0.00	\$42,000.00	\$0.00	\$2,100.00
	MAINTENANCE BUILDING ROOF LABOR	\$82,500.00	\$82,500.00	\$0.00	\$0.00	\$0.00	\$82,500.00	\$0.00	\$4,125.00
	ISO TAPER OPERATIONS	\$23,940.00	\$23,940.00	\$0.00	\$0.00	\$0.00	\$23,940.00	\$0.00	\$1,197.00
	MBCI ROOF MATERIALS OPERATION	\$111,453.00	\$111,453.00	\$0.00	\$0.00	\$0.00	\$111,453.00	\$0.00	\$5,572.65
	MBCI ROOF MATERIALS MAINTENANCE	\$122,156.00	\$122,156.00	\$0.00	\$0.00	\$0.00	\$122,156.00	\$0.00	\$6,107.80
	TECTUM 2" THICK	\$113,850.00	\$113,850.00	\$0.00	\$0.00	\$0.00	\$113,850.00	\$0.00	\$5,692.50
	ALUMINUM CURBS AND EXHAUST VENTS RELOCATION	\$7,000.00	\$7,000.00	\$0.00	\$0.00	\$0.00	\$7,000.00	\$0.00	\$350.00
	TRASH DISPOSAL	\$8,000.00	\$8,000.00	\$0.00	\$0.00	\$0.00	\$8,000.00	\$0.00	\$400.00
	OH AND PROFIT	\$135,598.00	\$135,598.00	\$0.00	\$0.00	\$0.00	\$135,598.00	\$0.00	\$6,779.90
	EAVE GALVANIZED STEEL ANGLE ALLOWANCE	\$1,000.00	\$0.00	\$1,000.00	\$0.00	\$0.00	\$1,000.00	\$0.00	\$50.00
	BETTERMAN ALLOWANCE	\$446.78	\$0.00	\$446.78	\$0.00	\$0.00	\$446.78	\$0.00	\$22.34
	ADD ALTERNATE NO. 1								
	MOBILIZATION	\$5,595.00	\$5,595.00	\$0.00	\$0.00	\$0.00	\$5,595.00	\$0.00	\$279.75
	FABRICATION								
	FACTORY CUTTING STEEL	\$16,497.00	\$16,497.00	\$0.00	\$0.00	\$0.00	\$16,497.00	\$0.00	\$824.85
	WELDING FABRICATION	\$12,500.00	\$12,500.00	\$0.00	\$0.00	\$0.00	\$12,500.00	\$0.00	\$625.00
	DRILLING FABRICATION	\$12,500.00	\$12,500.00	\$0.00	\$0.00	\$0.00	\$12,500.00	\$0.00	\$625.00
	PRIMER PAINT	\$1,000.00	\$1,000.00	\$0.00	\$0.00	\$0.00	\$1,000.00	\$0.00	\$50.00
	ASSEMBLY								
	MARINE COAT PAINT	\$1,000.00	\$1,000.00	\$0.00	\$0.00	\$0.00	\$1,000.00	\$0.00	\$50.00
	CLEVIS WELDING	\$2,000.00	\$2,000.00	\$0.00	\$0.00	\$0.00	\$2,000.00	\$0.00	\$100.00
	DRILLING CMU WALL	\$3,500.00	\$3,500.00	\$0.00	\$0.00	\$0.00	\$3,500.00	\$0.00	\$175.00
	BOLTING	\$1,000.00	\$1,000.00	\$0.00	\$0.00	\$0.00	\$1,000.00	\$0.00	\$50.00
	CANOPY ERRECTION	\$4,903.00	\$4,903.00	\$0.00	\$0.00	\$0.00	\$4,903.00	\$0.00	\$245.15
	PBR PANNELS	\$9,500.00	\$9,500.00	\$0.00	\$0.00	\$0.00	\$9,500.00	\$0.00	\$475.00

PROJECT: EL METRO OPERATION AND MAINTENANCE BUILDING ROOF REPLACEMENT AND BUILDING IMPROVEMENTS

APPLICATION NUMBER: Six (6) Final
 APPLICATION DATE: 10-Mar-17
 PERIOD FROM: 20-Dec-16
 PERIOD TO: 10-Mar-17

A ITEM NO.	B DESCRIPTION OF WORK	C SCHEDULED VALUE	D WORK COMPLETED		E THIS PERIOD	F MATERIALS PRESENTLY STORED (NOT IN D OR E)	G TOTAL COMPLETED AND STORED TO DATE (D + E + F)	H BALANCE TO FINISH (C - G)	I RETAINAGE (IF VARIABLE RATE) 5%
			FROM PREVIOUS APPLICATION (D + E)						
	ADD ALTERNATE NO. 2								
	LOCKERS AND BENCHES	\$10,779.00	\$10,779.00	\$0.00	\$0.00	\$0.00	\$10,779.00	\$0.00	\$538.95
	ACCESSORIES	\$3,327.14	\$3,327.14	\$0.00	\$0.00	\$0.00	\$3,327.14	\$0.00	\$166.36
	PARTITIONS	\$5,473.00	\$5,473.00	\$0.00	\$0.00	\$0.00	\$5,473.00	\$0.00	\$273.65
	INSTALLATION LABOR	\$3,500.00	\$3,500.00	\$0.00	\$0.00	\$0.00	\$3,500.00	\$0.00	\$175.00
	PLUMBING	\$21,401.00	\$21,401.00	\$0.00	\$0.00	\$0.00	\$21,401.00	\$0.00	\$1,070.05
	ELECTRICAL	\$9,890.00	\$9,890.00	\$0.00	\$0.00	\$0.00	\$9,890.00	\$0.00	\$484.50
	SUSPENDED CEILING	\$10,000.00	\$10,000.00	\$0.00	\$0.00	\$0.00	\$10,000.00	\$0.00	\$500.00
	CABINETS	\$3,000.00	\$3,000.00	\$0.00	\$0.00	\$0.00	\$3,000.00	\$0.00	\$150.00
	SHELVES	\$2,000.00	\$2,000.00	\$0.00	\$0.00	\$0.00	\$2,000.00	\$0.00	\$100.00
	CONCRETE BASE	\$3,500.00	\$3,500.00	\$0.00	\$0.00	\$0.00	\$3,500.00	\$0.00	\$175.00
	TILE LABOR	\$1,800.00	\$1,800.00	\$0.00	\$0.00	\$0.00	\$1,800.00	\$0.00	\$90.00
	SUPERVISION	\$12,500.00	\$12,500.00	\$0.00	\$0.00	\$0.00	\$12,500.00	\$0.00	\$625.00
	OH AND PROFIT	\$42,829.86	\$42,829.86	\$0.00	\$0.00	\$0.00	\$42,829.86	\$0.00	\$2,141.49
	TILE MATERIAL ALLOWANCE	\$1,000.00	\$1,000.00	\$0.00	\$0.00	\$0.00	\$1,000.00	\$0.00	\$50.00
	WALL, COVES AND BULLNOSE MATERIAL ALLOWANCE	\$800.00	\$800.00	\$0.00	\$0.00	\$0.00	\$800.00	\$0.00	\$40.00
	BETTERMAN ALLOWANCE								
	CAEA #1 - Canopy Modifications	\$25,473.25	\$25,473.25	\$0.00	\$0.00	\$0.00	\$25,473.25	\$0.00	\$1,273.66
	CAEA #2 - Restroom Floor Tile Replacement	\$6,830.85	\$6,830.85	\$0.00	\$0.00	\$0.00	\$6,830.85	\$0.00	\$341.54
	CAEA #3 - Extra Roof Huggers/Entrance Canopy	\$7,249.12	\$0.00	\$7,249.12	\$0.00	\$0.00	\$7,249.12	\$0.00	\$362.46
	Change Order #1								
		(\$1,446.78)	\$0.00	(\$1,446.78)	\$0.00	\$0.00	(\$1,446.78)	\$0.00	(\$72.34)
TOTAL		\$948,343.22	\$941,094.10	\$7,249.12	\$0.00	\$0.00	\$948,343.22	\$0.00	\$47,417.16

BASE BID	\$708,441.78	\$706,995.00	\$1,446.78	\$0.00	\$708,441.78	100.0%	(\$0.00)	\$35,422.09
ADD ALTERNATE NO. 1	\$69,995.00	\$69,995.00	\$0.00	\$0.00	\$69,995.00	100.0%	\$0.00	\$3,499.75
ADD ALTERNATE NO. 2	\$131,800.00	\$131,800.00	\$0.00	\$0.00	\$131,800.00	100.0%	\$0.00	\$6,590.00

CITY OF LAREDO
CITY OF LAREDO ENGINEERING DEPARTMENT
 1110 HOUSTON STREET LAREDO, TEXAS 78040

CONTINGENCY ALLOWANCE EXPENDITURE AUTHORIZATION
EL METRO ROOF REPLACEMENT AND RESTROOM IMPROVEMENTS
AUTHORIZATION NO. 2

Contractor: ABBA Construction, LLC
 P.O. BOX 451441
 Laredo, Texas 78045
 956-324-9343

Architect: Sepulveda Associates Architects, Inc.
 1820 Houston Street
 Laredo, Texas 78040
 956-725-1985

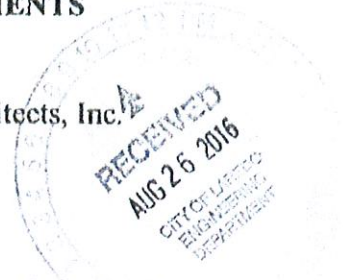

ABBA Construction, Inc. is hereby authorized to perform the following scope of work and adjust the allowance sum accordingly, as indicated below. *This is not a change order and does not modify the contract amount.*

The following items are herein accepted by the City of Laredo: Item 1, and 2 per below.

NO.	DESCRIPTION	STARTING BAL.	PROPOSED COST	ENDING BAL.
	CONTINGENCY ALLOWANCE	\$40,000.00		\$40,000.00
1.	Maintenance Building Structural Canopy Modifications		\$24,473.25	\$14,526.75
2	Operations Building Restroom Floor Tile Replacement		6,830.85	\$7,695.90
3				
	BAL. CONTINGENCY ALLOWANCE			7,695.90\$

ORIGINAL CONTRACT SUM: \$949,790.00
 NET CHANGE BY PREVIOUS CHANGE ORDERS \$ 0.00
THE CONTRACT SUM \$949,790.00

Roberto J. Sepulveda, AIA, Project Architect
 Sepulveda Associates Architects, Inc.

8-24-16
 Date

Jacob C. Flores, President
 ABBA Construction, Inc.

8/24/16
 Date

Joe Jackson, Asst. General Manager of Maintenance
 Laredo Transit Management, Inc.

8-24-16
 Date

Rogelio Rivera, P.E., City Engineer
 City of Laredo Engineering Department

8/29/16
 Date

See Attachments.